

JOB:

ITEM #:

QUANTITY:

Adjust-A-Shelf

T-BAR SERIES

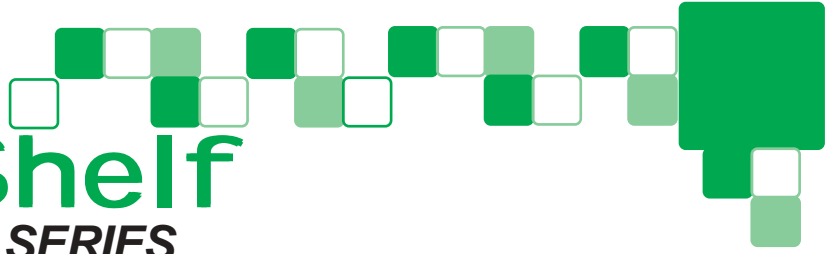

A
D
J
U
S
T
-
A
-
S
H
E
L
F
.
T
-
B
A
R
S
E
R
I
E
S

Specifically Designed For "High-Use" Areas

Approved for use in freezers, displays, as well as packaging and storage areas, these heavy duty aluminum shelves keep heavier product organized. With a **weight capacity of 1500# per shelf**, these units will hold almost anything! Unique T-Bar construction allows for easy-on, easy-off of product for easy storage while providing maximum air circulation.

Design Your Own Custom Unit

All four series of "Adjust-A-Shelf" Shelving, the same length and width are interchangeable. This allows you to custom make your own complete units with the type of shelving (H.D., T-Bar, Solid) you need. Each unit assembles in minutes with only an allen wrench.

Guaranteed To Last

Guaranteed to last, each rack carries a **Lifetime Guarantee** against rust and corrosion as well as a **Lifetime Guarantee** against material defects and workmanship.

Mobile Units -- Optional

Make your unit mobile by adding a 5" caster upgrade. Easily installed, the swivel stem type casters will take your shelving unit where it needs to go.



The wide T-Bar extrusion along with 1-3/4" spacing between "T"s provides more welds per "T" and more shelf surface, minimizing product "sag-through" while still providing adequate air flow.

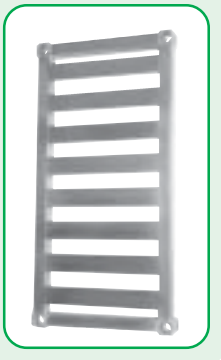

NSF Certified



Aluminum Food Handling, Storage, & Transport Solutions

New Age Industrial Corp., Inc. • 1000 E Hwy-36 • PO Box 520 • Norton, Kansas 67654

Phone#: 800.255.0104 • 785.877.5121 • Fax#: 877.877.7687 • 785.877.2616 • www.newageindustrial.com



JOB:

ITEM #:

QUANTITY:

SPECIFICATIONS

SHELVES: The construction of the T-Bar Series shelves incorporates a rectangular frame of 1-½" x 1-¾" x .070 wall extruded aluminum tube with 1-¼" x 2-¼" x .100 T-Bar welded inside, perpendicular to the shelf length. Each shelf corner has a heavy duty extruded aluminum collar permanently welded in place which accommodates the post. A stainless steel set screw is provided in each collar to lock the shelf at the desired height.

LOAD CAPACITY: The load capacity for each shelf is 1500#. Recommended load capacity for mobile units is 1200# gross cart weight.

POSTS: -- Sold Separately The uprights are extruded aluminum pipe (6063-T5 alloy) with an outside diameter of 1-⁵/₁₆" and a wall thickness of .150. Each upright is marked in two inch increments and fitted with plastic caps in each end.

CASTERS: -- Model #C440 Sold Separately Uprights can be fitted with four stem type 5" swivel casters, two with brake. Rated capacity per caster is 300#.



NSF Certified

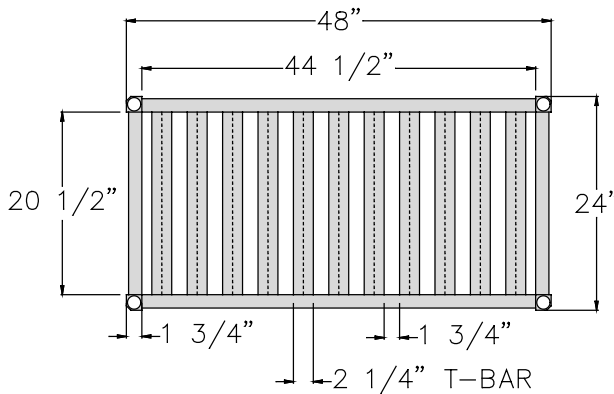

#2048TB Shelf

Individual T-Bar Shelves

Model No.	Size D-L	Ship Wt.
◦ 1530TB 15" x 30" 6#
◦ 1536TB 15" x 36" 7#
◦ 1542TB 15" x 42" 8#
◦ 1548TB 15" x 48" 10#
◦ 1554TB 15" x 54" 10#
◦ 1560TB 15" x 60" 11#
◦ 1566TB 15" x 66" 12#
◦ 1572TB 15" x 72" 13#
◦ 1830TB 18" x 30" 7#
◦ 1836TB 18" x 36" 8#
◦ 1842TB 18" x 42" 9#
◦ 1848TB 18" x 48" 11#
◦ 1854TB 18" x 54" 12#
◦ 1860TB 18" x 60" 13#
◦ 1866TB 18" x 66" 14#
◦ 1872TB 18" x 72" 16#
◦ 2030TB 20" x 30" 8#
◦ 2036TB 20" x 36" 9#
◦ 2042TB 20" x 42" 10#
◦ 2048TB 20" x 48" 12#
◦ 2054TB 20" x 54" 13#
◦ 2060TB 20" x 60" 14#
◦ 2066TB 20" x 66" 15#
◦ 2072TB 20" x 72" 17#
◦ 2430TB 24" x 30" 9#
◦ 2436TB 24" x 36" 11#
◦ 2442TB 24" x 42" 12#
◦ 2448TB 24" x 48" 14#
◦ 2454TB 24" x 54" 15#
◦ 2460TB 24" x 60" 17#
◦ 2466TB 24" x 66" 18#
◦ 2472TB 24" x 72" 20#

◦ All Items Are UPS-able

Posts

Model No.	Length	Ship Wt.
◦ 12P 12" 6#
◦ 34P 34" 2#
◦ 48P 48" 2.5#
◦ 54P 54" 3#
◦ 68P 68" 3.5#
◦ 72P 72" 3.5#
◦ 76P 76" 4#
◦ 84P 84" 4.5#

Capped aluminum pipe (1-⁵/₁₆" o.d.). Marked in 2" increments.

◦ All Items Are UPS-able

Aluminum Food Handling, Storage, & Transport Solutions

PHONE#: 800.255.0104 • 785.877.5121 • FAX#: 877.877.7687 • 785.877.2616