

Fry Kettle

Model CF-400G



Available in natural or propane gas, the Giles Gas Fry Kettle will cook 12-14 pounds of crispy, moisturized fried chicken, as well as other mouthwatering foods.

The completely automatic "Auto-Basket Lift," on the Giles Gas Fry Kettle, enables the operator to load the fryer, set the timer and activate the basket lift in one step. When the pre-set time for the frying is complete, the Auto-Basket Lift automatically raises the finished product out of the oil to avoid over cooking.

Constructed of durable, polished stainless steel, the CF-400G is also equipped with casters for easy cleaning and maintenance, ensuring years of efficient, attractive service.

Design Features

Automatic Oil Filtration System

Designed to complete a filter cycle within five minutes, the Automatic Oil Filtration System, which uses disposable filter paper, allows the operator to wash, rinse, drain, and filter the oil in one motion. Refilling the Giles Gas Kettle Fryer is automatic. The system will help increase shortening life by 50%.



Patented Gas Heat Exchanger

The exceptional design of the Giles Heat Exchanger allows for a true "cold zone" and a more efficient heat transfer resulting in an increase in energy savings. The Heat Exchanger heats the shortening evenly inside the pot in a 360° radius from the sides of the pot. This special patent delivers 43,250 BTUs using natural or propane gas.



Listings



Giles Foodservice Equipment

An ISO 9001 Registered Company

2750 Gunter Park Drive West • Montgomery, AL 36109 USA

334.272.1457 • Fax 334.272.3561 • Phone Toll Free 1.800.554.4537

Web Site: www.gilesent.com • Email: info@gilesent.com

[BACK TO INDEX](#)

Fry Kettle

Model CF-400G

Item No.: _____
 Quantity: _____
 Project Name: _____
 SIS#: _____
 AIA/CSI#: _____

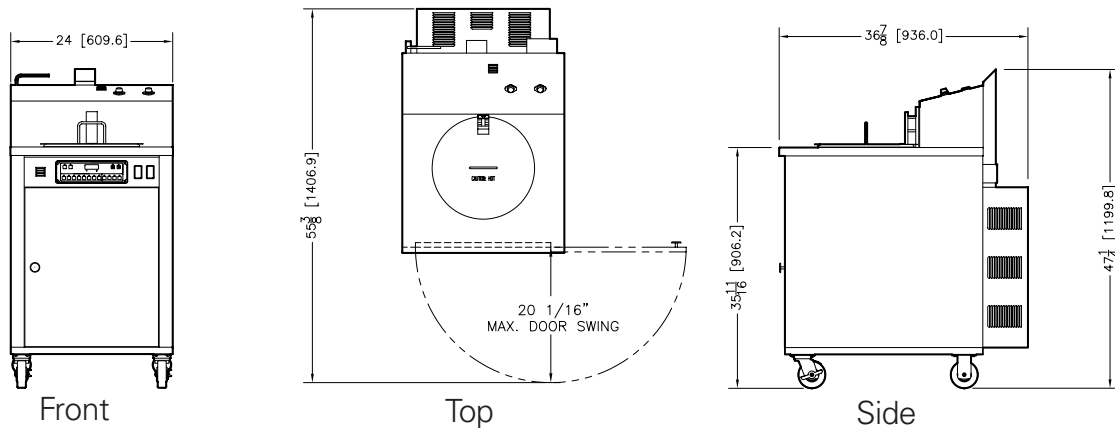

Inches [millimeters]

Specifications

We reserve the right to change specifications and product design without notice. Such revisions do not entitle the buyer to corresponding changes, improvements additions or replacements on previously purchased equipment.

Construction:

Cabinet and Fry Vat: 20Ga to 18Ga Stainless Steel
 Heating: Patented Heat Exchanger

Dimensions:

Width: 24" [610 mm]
 Depth: 36-7/8" [936 mm]
 Height: 47-1/4" [1162 mm]
 Fry Vat: 15-3/16" Depth X 13-7/8" Diameter [386 mm X 352 mm]
 Fry Basket: 14-5/8" Depth X 10-1/2" Diameter [391 mm X 184 mm]

Cooking Controls:

Computer controller 8 programmable menus, containing a cooking temperature and a time
 Temperature Range: 200° - 350°F [93° - 177°C]
 High Limit Thermostat: 425°F [220°C]

Capacity:

Shortening Capacity: 36 lbs. [16.3 kg]
 Production Capacity: 12-14 lbs. chicken

Electrical Specifications:

Available voltages: 120/208/230V
 1 phase - 120V - 7 AMPS
 3 Phase- 208/230 - 4 AMPS
 (Service cord provided on 120V only)

Gas Specifications: *(Installation instructions must be followed)*

1/2" Gas Line input with in-line regulator (not supplied)
 Propane 10.5 W.C. Natural 3.5 W.C.

Listings:

UL (US and Canada), CE, NSF

Product Designation:

CF-400G

Shipping Specifications:

Crated Weight: 390 lbs [177 kg]
 Crated Cube Size: 42" X 30" X 56" = 41 cu ft
 [1067mm X 762mm X 1423mm = 1.1 cu meters]

Accessories Included

Unit is shipped with (1) Fry basket, (1) Drain hose wand, (5) Filter paper sheets, (1) Pot brush, (1) Kettle drain brush, (1) Stir paddle, (1) Crumb shovel and (1) Manual.

How To Specify

1. Electrical Options

Specify the part number from the following:

	Voltage	H _z	Phase	Load Configuration	Part Number	Type
<input type="checkbox"/>	120	60	1	Delta	79198	LP
<input type="checkbox"/>	120	60	1	Delta	79192	Nat
<input type="checkbox"/>	208	60	1	Delta	79176	LP
<input type="checkbox"/>	208	60	1	Delta	79175	Nat
<input type="checkbox"/>	240	60	1	Delta	79183	LP
<input type="checkbox"/>	240	60	1	Delta	79182	Nat
<input type="checkbox"/>	230	50	1	Wye	70610	Both

2. Accessories*

Specify the part number and quantity of the following accessory items needed:

Qty	Description	Part Number
<input type="checkbox"/>	Fry Basket	38633
<input type="checkbox"/>	Filter Paper, (100) Sheets	60819
<input type="checkbox"/>	Filter Powder, (60) packets	72004
<input type="checkbox"/>	Boil Out (4) 8 lb containers	72003

*Additional charges

Giles Foodservice Equipment

2750 Gunter Park Drive West • Montgomery, AL 36109 USA
 334.272.1457 • Fax 334.272.3561 • Phone Toll Free 1.800.554.4537
 Web Site: www.gilesent.com • Email: info@gilesent.com

3. Shipping

Specify the shipping method

BACK TO INDEX