

PRODUCT:

QUANTITY:

ITEM#:

## Designed Smart.

- Designed to cook and hold pre-cooked foods from frozen state.
- Perfect for soups, chilis, and other dishes that need a quick thaw during the cooking cycles and a gentle warming heat for serving.
- CW-2A model has unique "serpentine shaped" heating elements that evenly distribute heat throughout the unit.
- CW-1B utilizes a bottom mounted heating element and an aluminum transfer plate to provide superior heat.
- Provided with insulation to protect interior parts and countertops from heat build-up.
- CW-1B accepts an 11qt. inset, or with adaptor, a 7 or 4 qt. inset.
- Both models are provided with knob guards.

## Built Solid.

### Built to Last

- Constructed with heavy-duty stainless steel for long life.
- Inside liner made with stainless steel.
- Steel "element support" stabilizes heating elements and reflects heat toward food.

### Reliability backed by the Industry's Best Warranty

- The CW-2A and CW-1B are backed by a 1-year Parts and Labor warranty.
- The CW-2A is included in our "Enhanced Warranty" service that replaces new units with certain product issues through the convenience of direct factory shipments.
- Certified by the following agencies:



**MODEL CW-1B CLASSIC COOK & SERVE**



**MODEL CW-2A CLASSIC COOK & SERVE**

## APW Wyott Design Features

- Wet Usage 100°F to 212°F (38°C to 100°C) (recommended).
- Heavy-duty stainless steel for long life.
- Easy to clean.
- Thermostatically controlled.
- Great for buffets, serving lines, back bars or back-of-the-house.
- Handles breakfast, lunch and dinner.
- Pans and insets not included.

*See reverse side for product specifications.*

**APW Wyott Foodservice Equipment Company**

729 Third Avenue • Dallas, TX 75226 • 800-527-2100 • 1-214-421-7366 • Fax 1-214-565-0976

PRODUCT:

QUANTITY:

ITEM#:

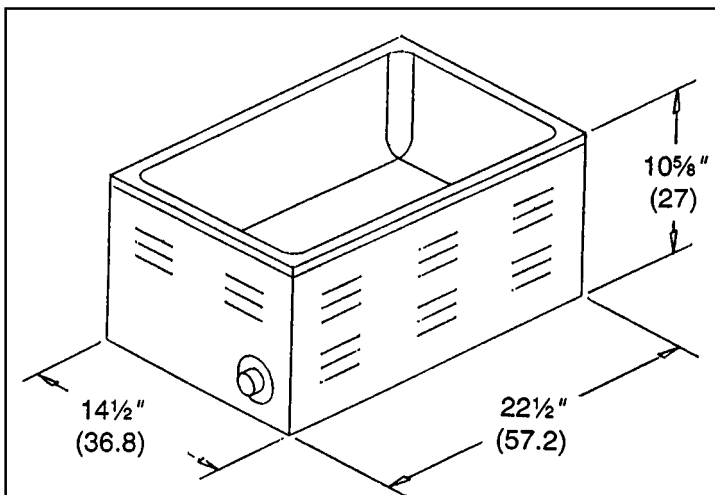

**Model CW-2A 12 x 20 22 Qt.  
Classic Cooker/Warmer**

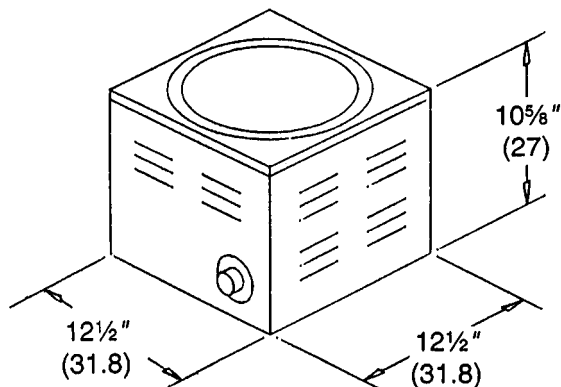

**Model CW-1B 11 Qt.  
Cooker/Warmer/Server**

Model CW-1B & CW-2A 12" x 20" Cook & Serve

## PRODUCT SPECIFICATIONS

### Construction:

Stainless steel housing and liner pan, fiberglass insulation.

### Dimensions:

CW-1B: 10<sup>5</sup>/<sub>8</sub>" H x 12<sup>1</sup>/<sub>2</sub>" W x 12<sup>1</sup>/<sub>2</sub>" D  
(27 cm x 32 cm x 32 cm)

CW-2A: 10<sup>5</sup>/<sub>8</sub>" H x 14<sup>1</sup>/<sub>2</sub>" W x 22<sup>1</sup>/<sub>2</sub>" D  
(27 cm x 37 cm x 57 cm)

### Electrical Information:

Each unit is equipped with a 60" three-wire grounded power cord which terminates with a standard three-prong male plug. The 120V unit uses a NEMA 5-15P plug. The 240V unit uses a NEMA 6-15P 90° plug.

### Electrical Specifications:

CW-1B: 120V, 800W, 6.7 Amps  
240V, 800W, 6.7 Amps

CW-2A: 120V, 1500W, 12.5 Amps  
240V, 1600W, 6.7 Amps  
208V, 1200W, 5.8 Amps

### Capacity:

CW-1B: 11 qt.

CW-2A: 22 qt.

### Ship Weight:

CW-1B: 16 lbs. (7.3 kg)

CW-2A: 29 lbs. (13.3 kg)

### CW-2A Options:

- Two 7 quart Adapter Plates (14883)
- Three 4 quart Adapter Plates (14886)
- One 7 qt./One 11 qt. Adapter Plate (14880)

### CW-1B Options:

- 7 quart Adapter Plate (55707)
- 4 quart Adapter Plate (55704)

F.O.B./ Dallas, TX

## World Class Support

World Class Sales Support to assist you with finding the right solution to your operation's needs. Call Customer Service at (800) 527- 2100 or Fax your request to 1-(214) 565-0976.

For more information about APW Wyott's World Class Support and High Performance Equipment, look us up on the Internet at [www.APWwyott.com](http://www.APWwyott.com)

Most Extensive Service System in the Industry! APW Wyott has two levels of service support for your needs:

- Direct Service Hot Line to Service Department, call (800) 527-2100.
- To find the Registered Service Technician in your area, call Automated Service Hot Line at (800) 733-2203.