

Fry Kettle
Model GEF-560



The Giles GEF-560 Fry Kettle cooks 56 pieces of crisp, moist fried chicken quickly and easily. To deliver maximum profits with minimum effort and expense, the GEF-560 utilizes low pressure frying with delicious results.

Constructed of durable polished stainless steel, the Giles GEF-560 is equipped with casters for convenient mobility and will roll through any standard door opening.

Fits into limited space for easy cleaning and simple maintenance, and still has the capacity to feed a hungry crowd.

Diversify your menu with this multi-purpose fryer to include mouthwatering seafood, vegetables and a variety of other tempting foods.

Design Features

Automatic Basket Lift

The Automatic Basket Lift enables the operator to load the fryer, set the timer and activate the basket lift in one step. When the frying cycle is complete, the basket is automatically raised out of the shortening, allowing for safe and easy unloading of the product.



Automatic Oil Filtration System

Designed to complete a filter cycle within five minutes, the Automatic Oil Filtration System, which uses disposable filter paper, allows the operator to wash, rinse, drain, and filter the oil in one motion. Refilling the Fry Vat is automatic. The system will increase your shortening life by 50%.



Listings



Giles Enterprises, Inc.

2750 Gunter Park Drive West • Montgomery, AL 36109 USA
334.272.1457 • Fax 334.272.3518 • Phone Toll Free 1.800.554.4537
Web Site: www.gilesent.com • Email: sales@gilesent.com

BACK TO INDEX

Fry Kettle

Model GEF-560

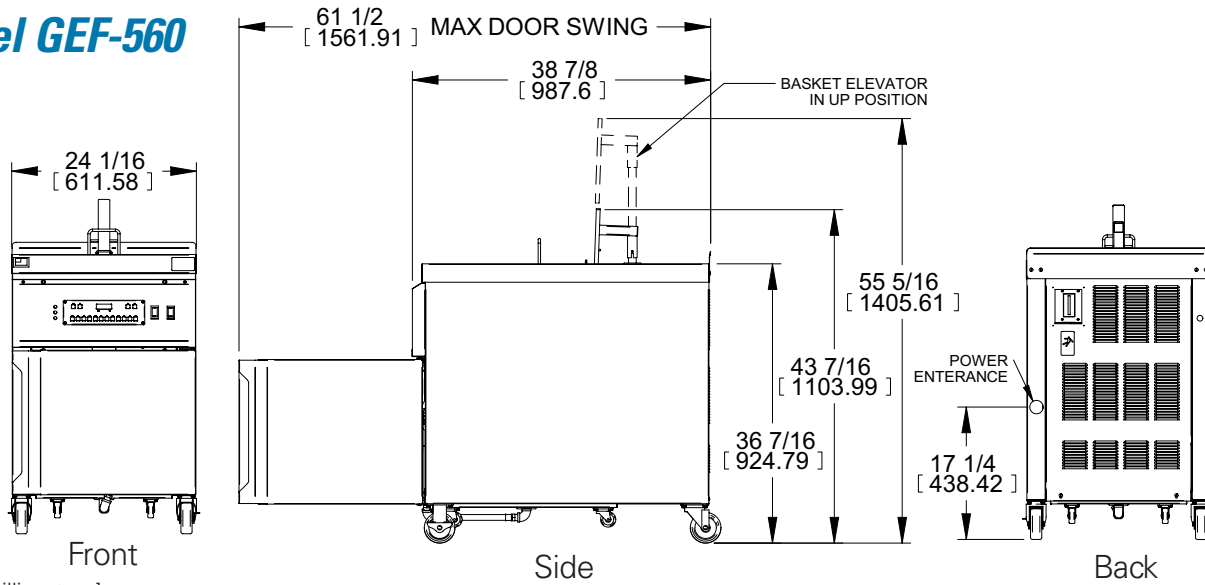

Inches [millimeters]

39124-A

Specifications

We reserve the right to change specifications and product design without notice. Such revisions do not entitle the buyer to corresponding changes, improvements additions or replacements or previously purchased equipment.

Construction:

Cabinet, Fry Vat, and Fry Basket: 20Ga to 16Ga Stainless Steel
 Door Swing: Reversible
 Heating Element: Incoloy Tubular Sheath

Dimensions:

Width: 24-1/16" [612 mm]
 Depth: 38-7/8" [988 mm]
 Height: 43-7/16" [1104 mm]
 Fry Vat: 18-5/8" diameter X 12-3/4" depth [473 mm X 324 mm]
 Fry Basket: 14-3/4" diameter X 10-1/4" depth [375 mm X 260 mm]

Cooking Computer:

8 Menu Items
 Range: 190° - 350°F [88° - 177°C]
 High Limit Thermostat: 425°F [220°C]

Capacity:

Shortening Capacity: 60 lbs. [27 kg]
 Production Capacity: 19 lbs. [9kg] chicken (56 pieces)

Electrical Specifications:

Available voltages: 208/220/240/380/415V 15,000 WATTS
 3 phase - 208/220/240V - 43/38/38 AMPS
 1 phase - 208/240V - 72/63 AMPS
 3 phase - 380/415V - 21 AMPS

(No service cord provided)

Product Designation:

GEF-560

Shipping Specifications:

Crated Weight: 464 lbs [211 kg]
 Crated Cube Size: 44" X 50" X 57" = 73 cu ft
 [1118mm X 1270mm X 1448mm = 2.1 cu meters]

Accessories Included

Unit is shipped with (1) Fry basket, (1) Fry basket cover, (1) Drain hose wand, (5) Filter paper sheets, (1) Pot brush, (1) Kettle drain brush, (1) Stir paddle, (1) Crumb shovel and (1) Manual.

How To Specify

1. Electrical Options

Specify the part number from the following:

	Voltage	H _z	Phase	Load Configuration	Part Number
<input type="checkbox"/>	208	60	1	Delta	70898
<input type="checkbox"/>	208	60	3	Delta	70897
<input type="checkbox"/>	240	60	1	Delta	70900
<input type="checkbox"/>	240	60	3	Delta	70899
<input type="checkbox"/>	220	50	3	Delta	70899
<input type="checkbox"/>	380	50	3	Wye	70916
<input type="checkbox"/>	415	50	3	Wye	70917

2. Accessories*

Specify the part number and quantity of the following accessory items needed:

Qty	Description	Part Number
<input type="checkbox"/>	Fry Basket	33703
<input type="checkbox"/>	Filter Paper, (100) Sheets	60810
<input type="checkbox"/>	Filter Powder, (60) packets	72004
<input type="checkbox"/>	Boil Out (4) 8 lb containers	72003

*Additional charges

3. Shipping

Specify the shipping method