

# CVap®



## HAD022 CVap® Holding Cabinet

**Full size model, fanless**

Electronic differential control - single dial

### General Specifications

- Winston's CVap holding cabinet with a single dial control is simplicity at its best. This unit controls the food temperature at a constant 160°F (71°C) while offering the flexibility to control the food texture from moist to very crisp.
- Patented Controlled Vapor Technology (U.S. patent #5,494,690) establishes that the water vapor content in the cabinet is the same as that of the food. This unique process controls moisture evaporation and saturation, so crisp foods stay crisp, moist foods stay moist.
- Built to last with quality craftsmanship, high grade stainless steel construction and full 1.5-inch (38mm) insulation on top, sides, and doors.
- Features full perimeter door gaskets, magnetic door handles, lift-off doors, removable side racks, and digital readout for water temperature.
- CVap equipment complies with all domestic, and most international requirements, such as UL, C-UL, UL Sanitation, CE, MEA, and others.
- This model has earned the ENERGY STAR®.

**Functions:** Holding

**Capacity:** 14 Sheet Pans  
18" x 26" x 1.25"  
(457mm x 660mm x 32mm)  
28 Steam Table Pans  
12" x 20" x 2.5"  
(305mm x 508mm x 64mm)  
14x2/1 Gastronorm Pans



Winston Industries, LLC.

**WINSTON**  
INDUSTRIES

Winston Products International, Ltd.



# HAD022 CVap® Holding Cabinet

## Full size model, fanless

Electronic processor control with single dial

Buy Winston Service Parts  
Online!  
Factory direct at  
[www.winstonind.com](http://www.winstonind.com)

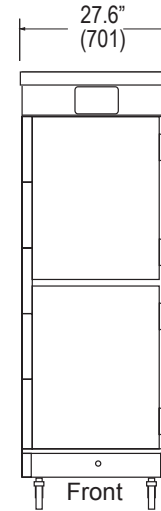
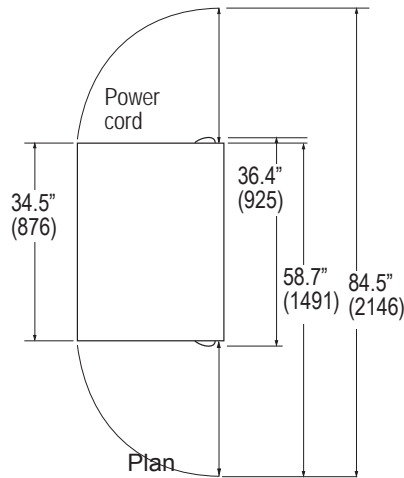
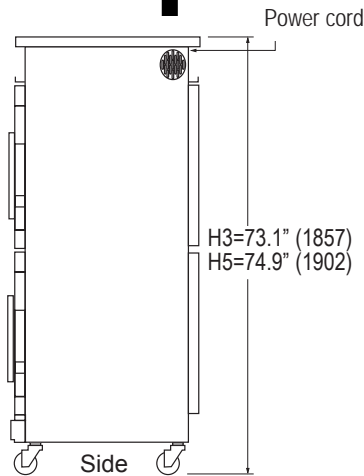

Drawings not to scale

Capacity	Size in (mm)	Volts	Hertz	PH	Amps	Watts	Circuit Amps	Ship Wt lb (kg)	Ship Cube ft (M)	Class	NEMA Plug Type
14 SP 28 STP 14x2/1 GP	H3=73.1" (1857) H5=74.9" (1902) HT=75.7" (1923) W=27.6" (701) WT=29.5" (749) D =34.5" (876) DT=37.6" (955) DP=36.4" (925)	<b>US/Canada</b>									
		120	60	1	17.6	2112	US 20 CAN 30	w/skid 355 (162)	60.1 (1.7)	100	5-20P United States 
<b>International</b>											
		230	50	1	9.2	2112	N/A	w/skid 355 (162)	w/skid call factory	N/A	5-30P Canada 

SP=Sheet Pan (18"x26"x1.25") • STP=Steam table pan (12"x20"x2.5") • GP=Gastronorm pan • H3=Height w/3" casters • H5=Height w/5" casters • HT=Height w/transport or bumper guard • WT=Width w/Transport or bumper guard • DT=Depth w/transport or bumper guard • DP=Depth with pass thru

### Short Form Specs

Shall be Winston CVap holding cabinet, model HAD022 with single dial control to provide precise food temperature at 160°F (71°C) and maintain food texture with settings from moist to very crisp. Utilizes Controlled Vapor Technology (patent #5,494,690) as a method and apparatus for holding hot foods, consisting of an air heater and water heater to establish ideal water vapor content that is in relation with the moistness characteristics for the food. Uniflo airflow design provides even heat distribution.

### Construction

**Materials:** To be commercial and institutional grade stainless steel to provide ease of cleaning and long service life with reasonable use and care.

**Racks:** Adjustable, normally spaced 3.5" (89 mm), to receive 14 sheet pans, 28 steam table pans, or 14 x 2/1 gastronorm pans. Removable for easy cleaning.

**Doors:** Field reversible hinges to allow door lift-off to facilitate cleaning. Magnetic door handles.

**Casters:** Includes 2 locking, 2 non-locking, heavy duty, non-marking

**Insulation:** Full-perimeter.

**Controller:** Single electronic automatic dial allows precise control of food temperature at 160°F (71°C) and allows food texture to be set automatically with moist to very crisp settings.

**Water fill:** Operated manually. Low mineral potable water is recommended, otherwise use deionizer/demineralizer to minimize corrosive damage.

**Ventilation:** Allow 2" (51mm) ventilation clearance on sides, back, and top of appliance. Install with supplied legs or casters. Refer to use & care manual for specific installation instructions.

Generally this appliance does not need to be installed under a mechanical ventilation system (vent hood). Check local health and fire codes for requirements specific to your location.

**Electrical:** Supplied with 7' (213cm) (minimum) power cord and plug. Load limit: 65 lbs. (29.25 kg) per rack.

### Warranty

Limited 1 year warranty (excluding gaskets, lamps, hoses, power cords, glass panels, and evaporators). Warranty disclaimer for failure to clean. Ask for complete warranty disclosure.

### Model Description

HAD022 CVap hold

Customer should specify the following when ordering:

1. **Caster preference (3" (76mm) casters or 5" (127mm) casters)**
2. **Any added options or accessories.**

### Options

Casters	3" (76mm) casters are standard. Optional 5" (127mm) caster upgrade available.
Pass Thru Windows	Second set of doors on back of cabinet
Pass Thru/Windows	Window in both doors
Solid Rack Supports	Second pair of doors on back of cabinet, windows in all doors
Bumper Guard Asm	Solid stainless steel rack supports (replaces standard wire rack supports)
Transport	Full-perimeter bumpers w/5" (127mm) casters (2 locking)
Water Fill System	Bumper guard base, cord wrap, evaporator cover, push/pull handles
Extended Warranty	Automatic water fill system
	Adds parts and labor warranty coverage for one additional year

### Accessories

PS2192/12	ScaleKleen™ packets (12 pack)
PS2206/4	Wire rack/tray (4-pack)
PS2359	One additional rack support (2 required)
PS2351	11" (279mm) Top cover extension
PS2553	8.5" (216mm) Top cover extension
PS2696	Mobile water removal system

Options and accessories available for an additional cost.

Winston Industries, LLC.



Winston Products International, Ltd.

2345 Carton Drive • Louisville, KY 40299 USA • (800) 234-5286 • (502) 495-5400 • Fax: (502) 495-5458 • [www.winstonind.com](http://www.winstonind.com)

Printed in USA.

Specifications subject to change without notice.

4272V023 Rev 26  
rs 5-08-08