



LP46 & LP56 Collectramatic®

Very Low Pressure/ Temperature Fryer

8 Channel programmable control

General Specifications



- Utilizes less than 25 percent of the pressure normally used in conventional pressure fryers.
- Takes full advantage of the modern poultry industry's 6 to 7 week chicken growth cycle, rather than the 14 to 16 week growth cycle of the 1950s. Today's chicken is much more tender, requiring less pressure and lower temperatures to cook.
- Taste is preserved by the patented system that limits food temperature to prevent flashing off of the aromatics of herbs and spices.
- Patented vent system is designed to limit pressure and to provide automatic relief against clogging.
- Very low pressure vent and microprocessor combine to improve operator safety over conventional high-pressure systems.
- Reduced training time.
- Fewer parts means lower maintenance costs.
- Easier to clean than a normal pressure fryer.
- Small footprint, only needs 4.72 square feet.
- Aqualert Water Detection software does not allow water to be boiled in the cooking vessel.
- Built to comply with applicable standards for manufacturers. Included are UL, C-UL, UL Sanitation, DEMKO, CE, and MEA.

Functions: Low Pressure Frying
Open Frying

Capacity:

LP46	
Product	12 lbs. (4 head) 5.5 kg.
LP56	
Product	18 lbs. (6 head) 8.2 kg.



Winston Industries, LLC.



Winston Products International, Ltd.



LP46 & LP56 Collectramatic®

Very Low Pressure / Temperature Fryer

8 Channel programmable control

Buy Winston Service Parts Online!
Factory direct at
www.winstonind.com

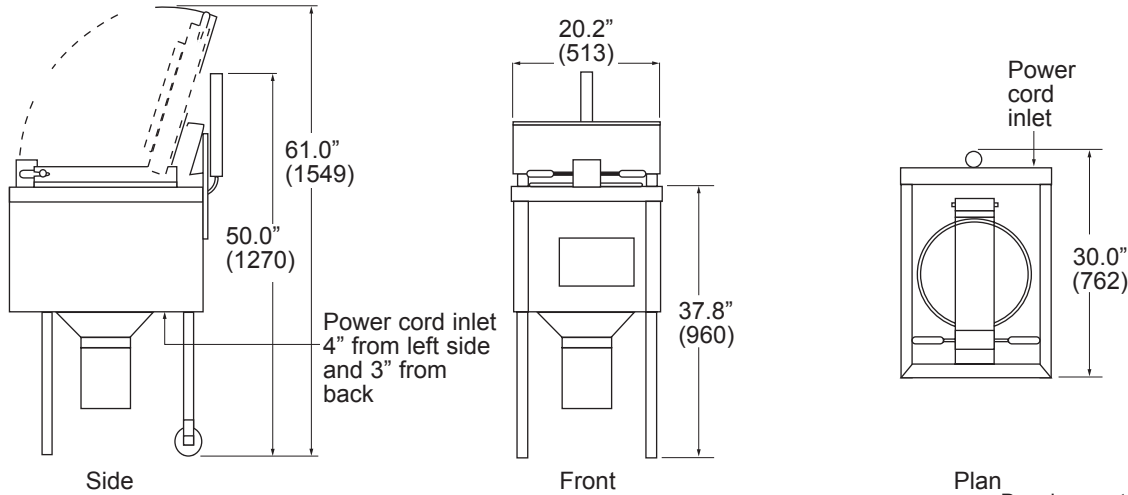

Plan
Drawings not to scale

Capacity	Size in (mm)	Volts	Hertz	PH	Amps	Watts	Circuit Amps	Ship Wt lb (kg)	Ship Cube ft (M)	Class
LP46 4 head 12 lb. (5.5 kg) product 64 lb. (28.8 kg) cooking oil	H =50.0 (1270)	208	60	3	29.2	10.5kw	50	165 (74)	20 (0.57)	85
	H2 =61.0 (1549)	240	60	3	25.2		50			
	W =20.2 (513)	240	60	1	43.7		60			
	D =30.0 (762)	Intl								
		400*	50	3	N/A		N/A	w/skid 204 lb/92 kg	w/skid call factory	
LP56 6 head 18 lb. (8.2 kg) product 75 lb. (33.8 kg) cooking oil	H =50.0 (1270)	208	60	3	29.2	10.5kw	50	175 (79)	20 (0.57)	85
	H2 =61.0 (1549)	240	60	3	25.2		50			
	W =20.2 (513)	240	60	1	43.7		60			
	D =30.0 (762)	Intl								
		400*	50	3	N/A		N/A	w/skid 214 lb/96 kg	w/skid call factory	

Short Form Specs

Shall be Winston Collectramatic very low pressure/temperature fryer, model LP46 or LP56 with processor controls to utilize gravity filtration allowing up to 240 lbs. (LP46) or 360 lbs. (LP56) of chicken (or equivalent) to be cooked without manual filtration or emptying collector; to utilize clamshell basket to maintain separation of product during cooking; for cooking a maximum of 12 lbs. (LP46) or 18 lbs. (LP56) of frozen or refrigerated chicken, fish, meats, or vegetables per load.

Construction

Materials: To be 16 - 20 gauge stainless steel mounted on four adjustable legs. Cooking vessel to be constructed of stainless steel.

Insulation: Full, 1-1/2" insulation around the cooking vessel.

Controller: Processor control with eight programmable channels.

Ventilation: Required. Check local codes.

Electrical: Refer to wiring schematic included in equipment for installation assistance. Cord/ Plug **not** included. Shipped wired for 3-phase application. Licensed electrician may be required. Check local codes.

Warranty

Limited 1 year warranty, excluding gaskets, lamps, hoses, power cords, and fryer baskets. Warranty disclaimer for failure to clean. Ask for complete warranty details.

Model

LP46
LP56

Description

Collectramatic low pressure/open fryer, 4-head
Collectramatic low pressure/open fryer, 6-head

Customer should specify the following when ordering:

1. **Electrical preference (208V, 240V, or 400V). Cordset is not included. All units shipped 3-phase.**

2. **Any added options or accessories.**

* *Inquire about additional international voltages available.*

Options

Extended Warranty Adds parts and labor warranty coverage for one additional year.

Included Accessories

1	Clamshell basket	1	Drain hook
2	Collector gaskets	1	Pair gloves
2	Lid gaskets	1	Plugging tool
1	Teflon® brush	1	Displacer
1	Long collector	1	Spatula
1	Heat plate		

Optional Accessories

PS1180	Utensil rack
PS1290	Open basket
PS1875	Basket lift assist

Options and accessories available for an additional cost.

Winston Industries, LLC.



Winston Products International, Ltd.