



Project: \_\_\_\_\_  
 Location: \_\_\_\_\_  
 Item #: \_\_\_\_\_  
 Quantity: \_\_\_\_\_

## Deep Well Horizontal Bottle Cooler

### VDW MODELS —

Black Vinyl on Steel Exterior Finish with  
 Stainless Steel Lids and Countertop.  
 Galvanized Steel Interior.

- VDW-50-18-1**
- VDW-65-24-1**
- VDW-80-32-1**
- VDW-95-38-1**



**VDW-50-18-1 Illustrated**

### Standard Features (all models)

- Black Vinyl on Steel Exterior with Stainless Steel Countertop
- Galvanized Steel Interior
- High-Density, Polyurethane Foam Insulation
- Adjustable Epoxy Coated Wire Product Dividers
- Horizontal Stainless Steel Insulated Lids Slide Under the Countertop into Rear Pocket
- Countertop with Integral Glass Stops
- Balanced, Self-Contained, Hermetically Sealed Refrigeration System
- Environmentally Friendly R-134a Refrigerant
- Maintains Ice-Cold Products 32°F to 38°F with Capacity to Spare
- Condensate Automatically Evaporated, No Plumbing Required
- Interior Floor Drain
- Anti-Corrosion Coated Evaporator Coil
- Direct Forced-Air Cooling System Chills Bottles on Top First
- Power Supply Cord and Plug Attached
- Mounted Bottle Opener and Cap Catcher

### Optional Features and Accessories

- Stainless Steel Exterior
- Heavy-Duty Swivel Casters with Brakes
- Lid Locks

#### Cabinet:

The cabinet is constructed of a black vinyl on steel exterior to maintain an attractive appearance for years of heavy use. Foamed-in-place polyurethane insulation throughout the cabinet ensures the ultimate in energy efficiency. Bottle cap opener and cap catcher is standard with all models.

Standard interior is galvanized steel. Included with the unit are adjustable epoxy coated steel wire product dividers.

#### Top:

The top of the deep well bottle cooler includes an easy slide stainless steel insulated lid(s) and stainless steel countertop with integral glass stops.

#### Refrigeration System:

The balanced, self-contained, hermetically sealed refrigeration system provides ample capacity to chill and hold products between 32°F and 38°F. The CFC free R-134a refrigerant is ozone friendly and environmentally safe. All condensate water is disposed of automatically by the energy efficient non-electric condensate evaporator, no plumbing is required. An 8' foot cord and plug set is included.

Approvals:		Victory Refrigeration specification sheets are available online at <a href="http://www.victory-refrig.com">www.victory-refrig.com</a> .
------------	--	---

CHARACTERISTICS	VDW-50-18	VDW-65-24	VDW-80-32	VDW-95-38
Width, Overall	50"	65"	80"	95"
Depth, Overall	26 1/2"	26 1/2"	26 1/2"	26 1/2"
Height, Overall	33 7/8"	33 7/8"	33 7/8"	33 7/8"
Lids	2	2	3	4
Dividers	3	4	5	6
No. of Cases (12 oz. cans)	23 3/4	34 3/4	45 3/4	55 3/4
No. of Cases (12 oz. bottles)	17 1/2	25 1/4	32	39
Capacity Net (cubic feet)	13.35	18.46	24.1	29.5
Cabinet Voltage	115/60/1	115/60/1	115/60/1	115/60/1
Condensing Unit Size (HP)	1/3	1/3	1/2	1/2
Total Amperes	6.3	6.3	9.5	9.5
NEMA Plug	5-15P	5-15P	5-15P	5-15P
Crated Dimensions	30x52x40	30x68x40	30x82x40	30x97x40
Gross Weight (Crated lbs.)	259	296	379	425

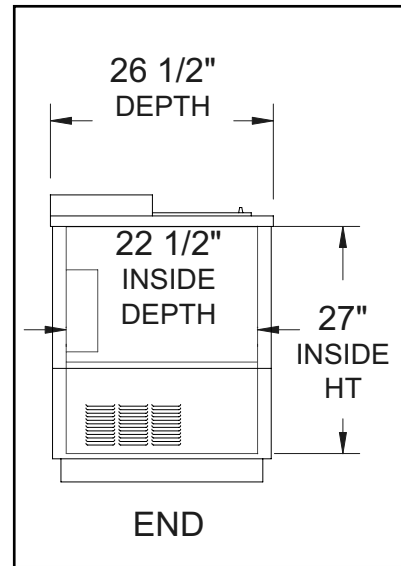

VDW-50,65,80 & 95

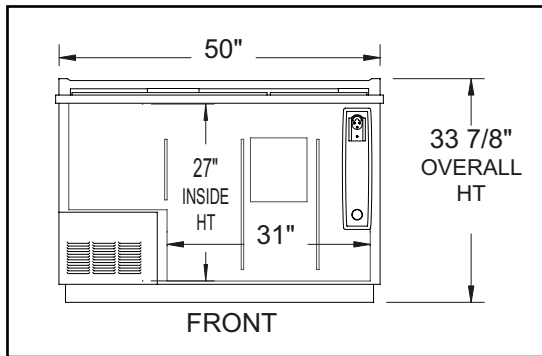

VDW-50-18-1

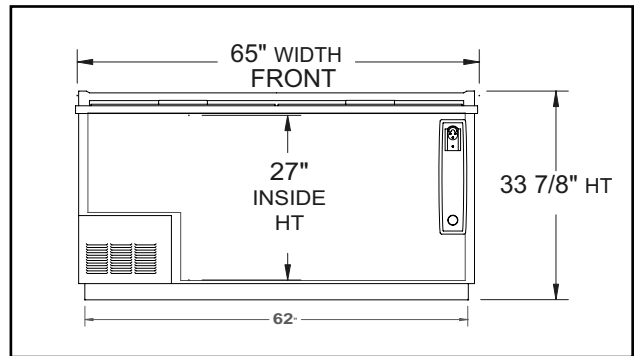

VDW-65-24-1

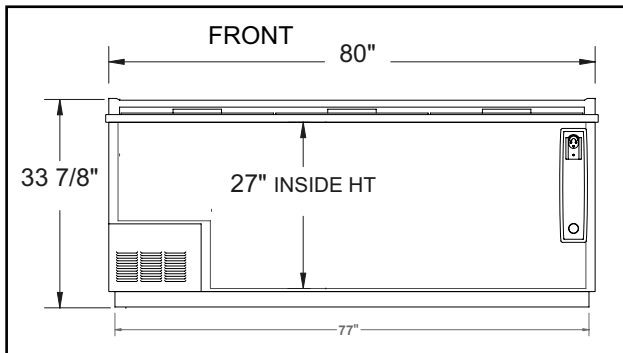

VDW-80-32-1

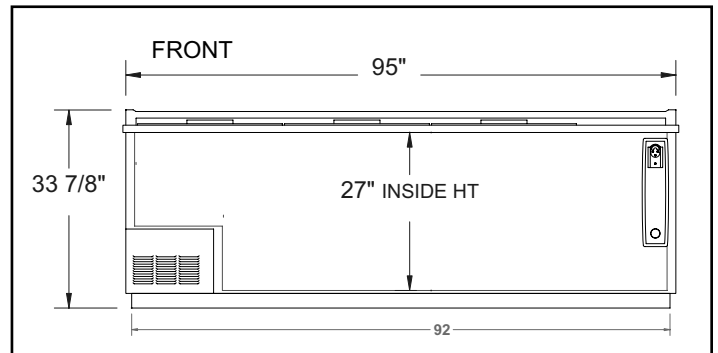

VDW-95-38-1

Continuous product development may necessitate specification changes and design without notice.



Victory participates in the KCL CADalog, the most current source of CAD symbols for foodservice designers worldwide. Symbols include standard equipment in plan, side, front and 3-D views, layered for FEDA/FCSI recommended guidelines.